

DATE: 27<sup>th</sup> October, 2024

INVITATION TO BID NO. MAP/MAUS/24/5355-32

**Bids Required for Rehabilitation/Construction of DWSS & WASH Facilities in District  
Bagh-AJ&K**

S #	Name of activity	Quantity (No)	Location
1.	Rehabilitation of <b>existing drinking Water supply Schemes (DWSS)</b>	02	Bagh, AJK
2.	Construction of WASH facilities (latrine blocks)	04	Bagh, AJK

TYPE OF PROCUREMENT: **Single stage two envelope process**CLOSING DATE AND TIME: **Monday 11<sup>th</sup> November, 2024 3:00 pm.****GENERAL INFORMATION**

The Office of the Muslim Aid (MAP) Islamabad invites -bids from qualified, Contractors/ vendors/suppliers / Authorized Dealers, duly registered with the government of the Islamic Republic of Pakistan and Pakistan Engineering Council to submit a firm offer for the "Rehabilitation/Construction of DWSS & WASH Facilities in Bagh-AJK". The construction firm offers from the successful bidders would form the basis for an award of a contract.

**BIDDING DOCUMENTS**

The following annexes form an integral part of this invitation to Bid:

Annex A: Detailed Specification of ITB / Drawings / Design for DWSS & WASH Facilities

Annex B: General Terms and Conditions for Purchase/supply of Goods

Annex C: Vendor Registration Form and Instruction for completion of bid

**SECTION I: BIDDING INFORMATION****a) ACKNOWLEDGMENT**

Bidders are requested to confirm the receipt of this **ITB** and send the expression of their intention to participate to the addresses (courier) provided in the "SUBMISSION OF BIDS" section of this ITB.

**b) QUERIES**

i) Bidders are required to submit all their **inquiries in respect of this Invitation to bid by e-mail to [procurement@muslimaid.org.pk](mailto:procurement@muslimaid.org.pk) by Thursday, 7<sup>th</sup> November, 2024: 5:00 p.m.** MUSLIM AID may, at its discretion, copy any reply to a particular question to all other invited Bidders.

**IMPORTANT:** Including copies of your offer with any correspondence sent directly to the attention of the responsible buyer will result in disqualification of the offer. Please send your offer directly to the address provided in this ITB's "SUBMISSION OF BIDS" section.

**c) YOUR OFFER**

Please submit your offer using the submission templates provided. It should conform to the following requirements and contain all information required. The offers not conforming to the requested format will not be considered for evaluation. Your offer should include the following information:

**DELIVERY TIME:** All items must be delivered to the specified locations as per the schedule given in Annex C OR AS SOON AS possible after placement of the confirmed order.

- **OFFERS** can be made for part of the requirement as listed in the attached **Annex-A (Lot 1 & 2)**

**COST:** The cost should include the Rehabilitation/Construction of DWSS & WASH Facilities including Transportation and all applicable taxes as per government law.

- **CURRENCY:** Your proposal must be prepared in a single currency, PAK Rupees.
- **LANGUAGE:** Bids shall be prepared in English.
- **INSPECTION:** All civil construction work Specifications are subject to inspection and will be advised at the time of delivery. The selected contractor/ Supplier will inform MUSLIM AID when the civil construction work / Supplies will be ready for inspection. The inspection will be arranged by MUSLIM AID. Please note that inspection charges resulting from the contractor's default will be charged directly to the contractor.
- **PLACE OF INSPECTION:** The inspection will be held at the sites, as per the sites identified by MUSLIM AID.
- **COUNTRY OF ORIGIN OF THE SUPPLIER AND AREA OF OPERATION:** The bid shall state the country in which the items are manufactured.
- **BID VALIDITY:** The bid submitted must remain valid for acceptance for 03 Months from the Invitation to Bid closing date.
- **VENDOR REGISTRATION:** Contractors/suppliers are requested to complete and submit with their offer the vendor registration form (Annex D), together with the necessary supporting documentation unless they have already been registered with **Muslim Aid (MAP)** and have received purchase orders within the last 3 years. All the companies are required to submit registration documents for example.
  - **Dealers/Partnership certificates issued by principal companies/organizations**
  - **Certificate of registration from PEC – Category C4 to C6)**
  - **Certificates of Work completed within the last 3 years or so**
  - **National Tax Number / STN**
  - **Update bank statement last one year.**
  - **Or any other document issued by a government regulatory body certifying the legality of their business.**

▪ **BID EVALUATION:**

**d.1) Supplier Registration**

The qualified supplier/ Contractor will be added to the vendor registration after investigation of suitability based on the submitted Vendor / Contractor Registration Form and supporting documents. The investigation involves consideration of several factors such as:

- Financial Standing (6 Monthly Bank Statement)
- Minimum three years of Previous experience in relevant civil work
- Core business
- Track record
- Minimum volume of annual work
- Technical Knowledge of the work under consideration
- Contract capacity
- Interested contracting companies must share the details of their technical staff along with the machinery.
- Potential bidders are informed that your application MUST accompany **3 % earnest money** as a call deposit in the form of a Demand Draft in the Name of **'Muslim Aid (MAP)** (Please note that the cheque or copy of Demand Draft will not be acceptable) This will be followed later by performance evaluation as a contractor such as:
  - Ability to respond quickly to the Agency's needs.
  - Timely Rehabilitation/Construction of Rehabilitation/Construction of DWSS & WASH Facilities in Bagh-AJK
- as per agreed design / Completion works as per quality and quantity with intime frame.
- Dependability of products and services.

**d.2) Financial and Technical Evaluation**

All bids from contractors will be evaluated based on:

- Compliance with the mentioned MUSLIM AID Specification and approved material as per samples
- Delivery Time / Completion of Work

**IMPORTANT:** For evaluation purposes only, the offers submitted in PKR currency

- **SUBMISSION OF BIDS**

**Bids must be submitted in 2 (two) separately sealed envelopes as follows: enclosed in 1 outer sealed Envelope:**

- 1 (one) sealed envelope containing technical part of the offer
- 1 (one) sealed envelope containing financial part of the offer

- **Sealed envelope containing:**

**Annex A: Detailed Specification of ITB and design for Rehabilitation of DWSS & WASH Facilities**

**Annex B: General Terms and Conditions for Purchase/supply of Goods/Rehabilitation/Construction of DWSS and WASH Facilities**

**Annex C: Vendor Registration Form and Instruction for completion of bid**

**A sealed envelope containing the Technical & Financial part of the offer (ANNEXURE A & B)**

**To be sent only through courier or by hand to the following addresses clearly marked as follows:**

**NOT TO BE OPENED BY THE REGISTRY**

**MAP/MAUSA/24/5355-32** (Bids Required for Rehabilitation/Construction of DWSS & WASH Facilities)

**MUSLIM AID Ad (MAP)**

**Plot # 1, First Floor, Executive Business**

**Centre, Main Double Road, FECHS, E-11/2,**

**Islamabad**

Offers submitted must be sealed as detailed below:

*a. the envelope should **be marked tender Number and addressed as above,***

**All Bids must be received by Monday 11<sup>th</sup> November, 2024: 3:00 p.m.**

**LATE SUBMISSION OF BIDS:** Bids received after the deadline for submission of BIDs and BIDs transmitted in any other manner than those indicated above will not be considered.

**BID ACCEPTANCE**

**MUSLIM AID** reserves the right to accept the whole or split. Please note **that the lowest offer is not the only criterion for acceptance of the offer). Muslim Aid has the right to select the contractor /Supplier against whole or split.**

MUSLIM AID may, at its discretion, extend the deadline for the submission of proposals, by notifying all prospective suppliers in writing. The extension of the deadline may accompany a modification of the solicitation documents prepared by MUSLIM AID at its own initiative or in response to a clarification requested by a prospective supplier.

**a) CURRENCY AND PAYMENT TERMS FOR Rehabilitation/Construction of DWSS & WASH Facilities in Bagh-AJK**

Any Contract/Purchase Order (PO) issued as a result of this ITB will be made in Pakistani Rupees. All Government taxes are applicable.

Yours sincerely,



M. Sulman Baig  
Procurement & Logistics Manager  
MUSLIM AID

Plot # 1, First Floor, Executive Business Centre,  
Main Double Road, FECHS E-11/2, Islamabad

**ANNEXURE A**
**LOT NO. 1**
**BoQ- MATERIAL COST/ABSTRACT OF COST**
**Rehabilitation of DWSS Al Shaikh Basti Bagh AJK**
**(DETAIL SPECIFICATION OF CIVIL CONSTRUCTION WORK AND MATERIAL SPECIFICATION)**

Sr #	DESCRIPTION/DETAIL SPECIFICATION	UNIT	QTY	UNIT RATE	TOTAL AMOUNT
1	Cement (Bestway, Fecto or equal)	42	Bags		
2	Sand (Larnespur) RWP	107	Cft		
3	Crush (local) 3/4 inch and Down Gauge	206	Cft		
4	Stones for soling and filling for plumb wall	6	Cft		
5	Pipes HDPE & GI (Disinfecting HDPE pipes density 700-960 kg/cu.m and carbon black contents > 2% with DIN-8074, 8075 or PS-3580:1997(rev.) ISO 9001-2000 pressure classification of PE -100 (black) for water PN-10				
6	20mm (HDPE .PN- 10) 1/2"	1600	Meter		
7	25mm (HDPE PN-10) 3/4"	800	Meter		
8	32mm (HDPE .PN-10) 1"	1100	Meter		
9	110 mm (HDPE .PN-10) 3" dia	350	Meter		
10	GI 0.5" Dia IIL or equal	140	Rft		
11	GI 1.00" Dia IIL or equal	16	Rft		
12	GI 1.25" Dia IIL or equal	6	Rft		
13	PVC pipe (4") for stand posts& Drainage	238	Rft		
14	PVC pipe (2"), for wastewater drainage	60	Rft		
15	Fittings 20% of pipe cost (HDP fitting straight cuppler threaded etc, & Gi fitting & walls China made)				
16	P/I of 5 distribution existing brunch network (Gi pipe 1.25-10ft, socket-1"-5no's, nipple 1"-5nos, union 1"-5nos, socket1/2"-30 no's, welding works @ 3000 per collection and overall, 5-collection point (Bouncry)	5	No		
17	Shuttering wooden or steel plate	40	Sft		
18	Steel cover (3'x2) for top roof of wall chamber with fixing 1.5"x1.5" angle iron and using of 18SWG iron sheet and 2 coat final painting. Approved by the Engineer.	2	No		

19	Water Storage Tank 1000 Gallon (3ply) 21CFR 177.1520(1) 3.1 and 3.2 for Storage of Potable Water.1 Inch Inlet & 1 Inch Outlet Bulkhead Poly Tank Fittings.16" Vented Manway	2	No		
20	providing and fixing High Quality Visibility Sign Board of 3'x4'Dimensions on 18 SWG iron sheet including GI pipes frame for supporting purpose of 1inch Dia placed at the height of at least 4.5 ft above the ground with strong concrete foundation of at least 1ft depth, painting with approved Color and logos and details of the project provided on site. As per Direction of engineer in charge.	1	No		

**Total Cost**
**2- LABOR COST**

Sr #	DESCRIPTION	Quantity	RATE PER DAY	TOTAL AMOUNT
1	Skilled Labour	9		
2	Unskilled Labour	29		

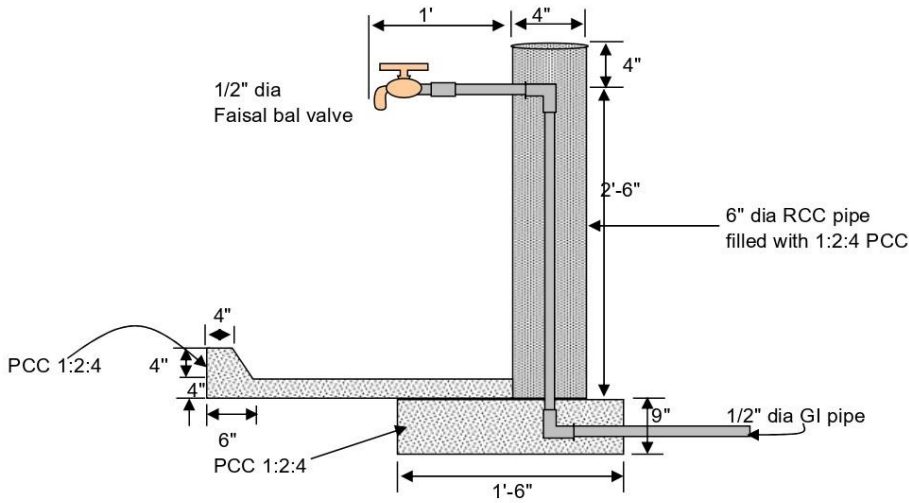

**X-Section of Stand Post**

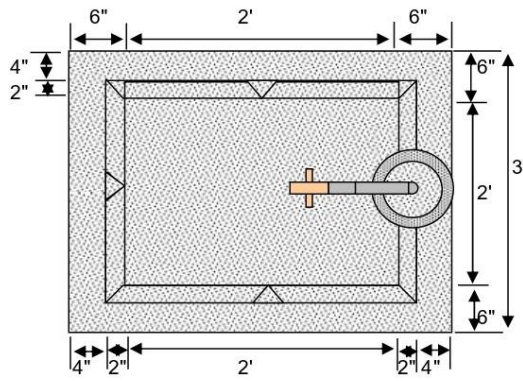

**Plan of Stand Post**

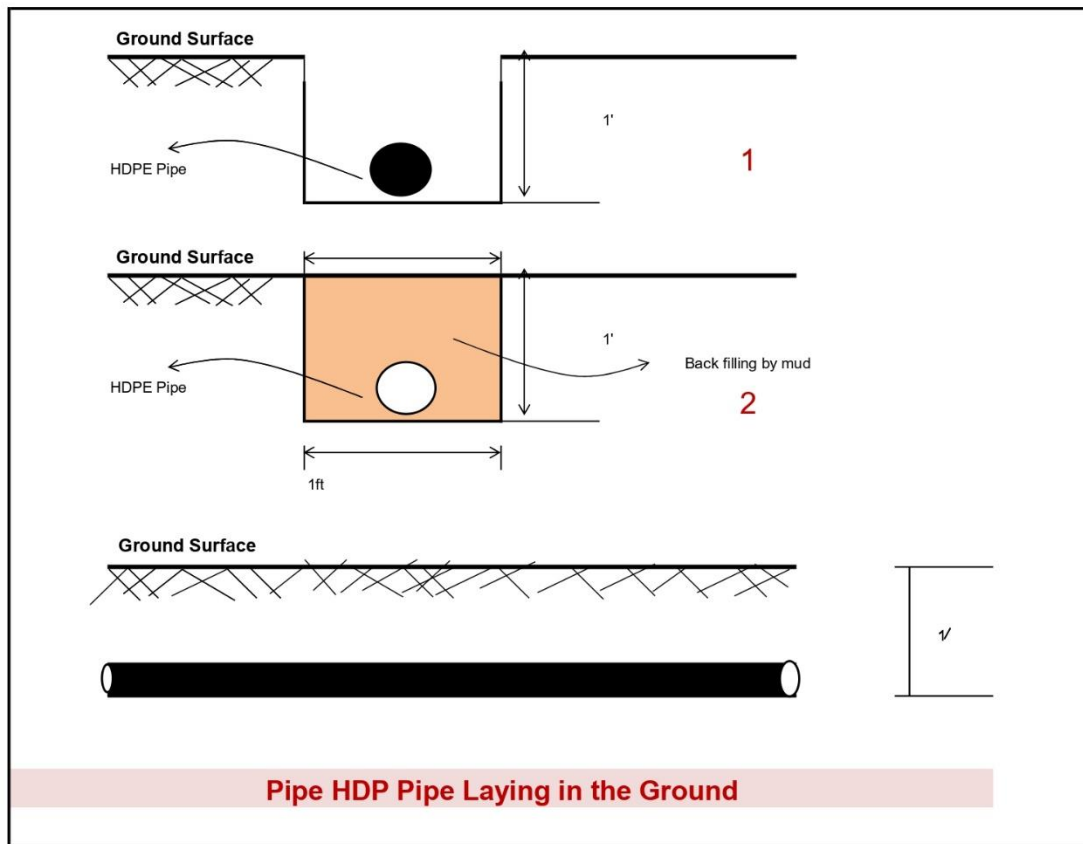

## BoQ- MATERIAL COST/ABSTRACT OF COST

### Rehabilitation of DWSS Major Camp Bagh AJK

Sr #	DESCRIPTION/DETAIL SPECIFICATION	UNIT	QTY	UNIT RATE	TOTAL AMOUNT
1	Cement; Bestway, Fecto, or equal	102	Bags		
2	Sand (Larnespur) RWP	284	Cft		
3	Crush (local) 3/4 inch and Down Gauge	492	Cft		
4	Painting with three coats of weather-resistant paint, including wall puttying of all outer walls and logo on surfacing, using approved paints and color pigments, complete in all respects as per the approval and direction of the engineer in charge.	240	Sft		
5	Stones for soling and filling for plumb wall	312	Cft		
6	Mild Steel 0.50inch Dia and attached Reinforcement Schedule	643	Kg		
7	20mm (HDPE .PN- 10) 1/2"dia	1600	Meter		
8	25mm (HDPE PN-10) 3/4"dia	1000	Meter		
9	32mm (HDPE .PN-10) Main line 1"dia	2400	Meter		
10	40 mm Dia (HDPE .PN-10) Main line 1.25"	1300	Meter		
11	GI 0.5" Dia IIL or equal	80	Rft		
12	GI 1" Dia IIL or equal	16	Rft		
13	GI 1.25" Dia IIL or equal	6	Rft		
14	UPVC pipe (4") for stand posts (Master or equal)	100	Rft		
15	UPVC pipe (2"), for waste water drainage (Master or equal)	50	Rft		
16	Fittings 20% of pipe cost (HDP fitting straight cuppler threaded etc ,& Gi fitting & walls China made)				
17	Shuttering wooden or steel plate	1238	Sft		
18	Steel cover (2'x2) for the top roof of wall chamber with fixing 1.5"x1.5" angle iron and using of 18SWG iron sheet and 2 coats final painting. Approved by the Engineer.	1	No		
19	Water Storage Tank 1000 Gallon (3ply) 21CFR 177.1520(1) 3.1 and 3.2 for Storage of Potable Water.1 Inch Inlet & 1 Inch Outlet Bulkhead Poly Tank Fittings.16" Vented Manway	2	No		



20	Providing and fixing High-Quality Visibility Sign Board of 3'x4'Dimensions on 18 SWG iron sheets including G.I pipes frame for supporting purpose of 1inch Dia placed at the height of at least 4.5 ft above the ground with strong concrete foundation of at least 1ft depth, painting with approved Color and logos and details of the project provided on site. As per Direction of engineer in charge.	1	No		
21	Head Carriage Road to tank site around 300 Meter	1	Jobs		

**Total Cost**
**2- LABOR COST**

Sr #	DESCRIPTION	Quantity	RATE PER DAY	TOTAL AMOUNT
1	Skilled Labour	51		
2	Unskilled Labour	106		

**PROPOSED DRAWING OF**  
**A. MAIN WATER TANK (EARTH QUAKE RESISTANT)**  
 Name of Schemes Major Camp Huda Bari

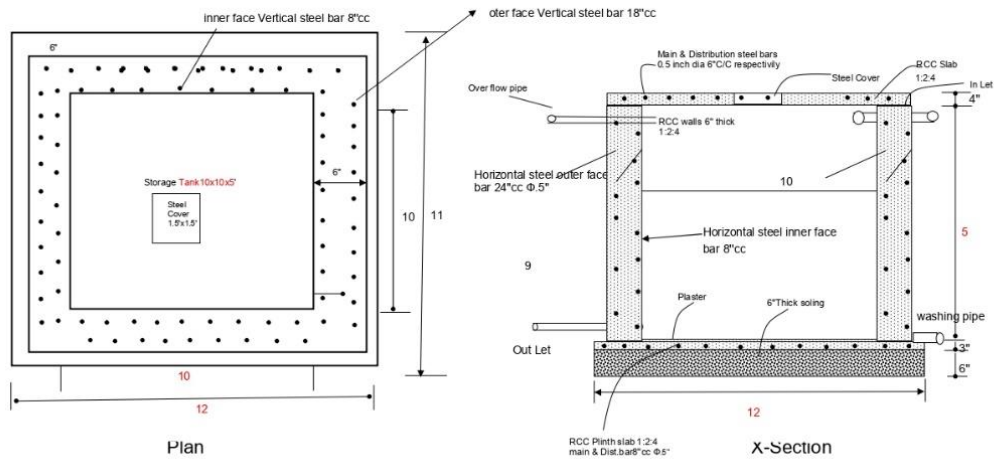

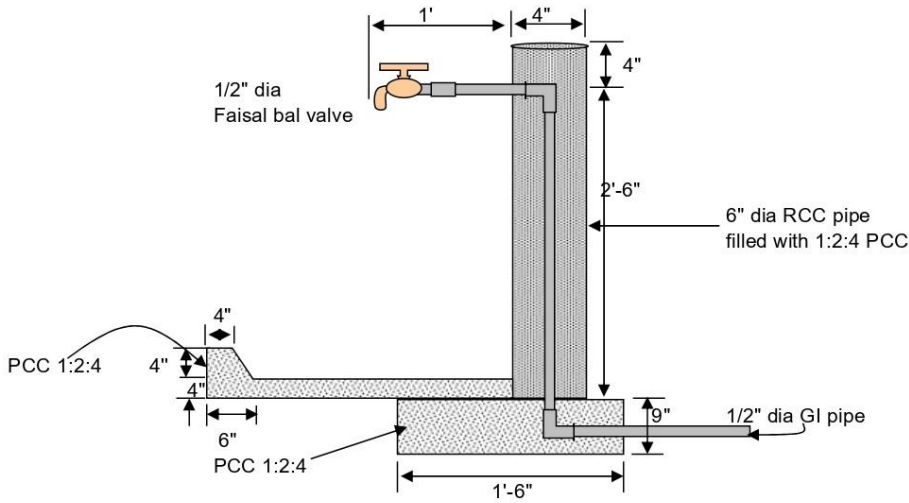

**X-Section of Stand Post**

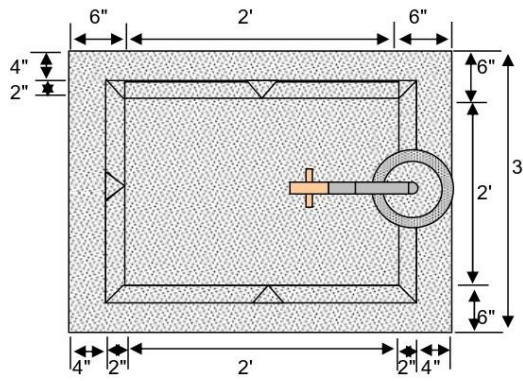

**Plan of Stand Post**

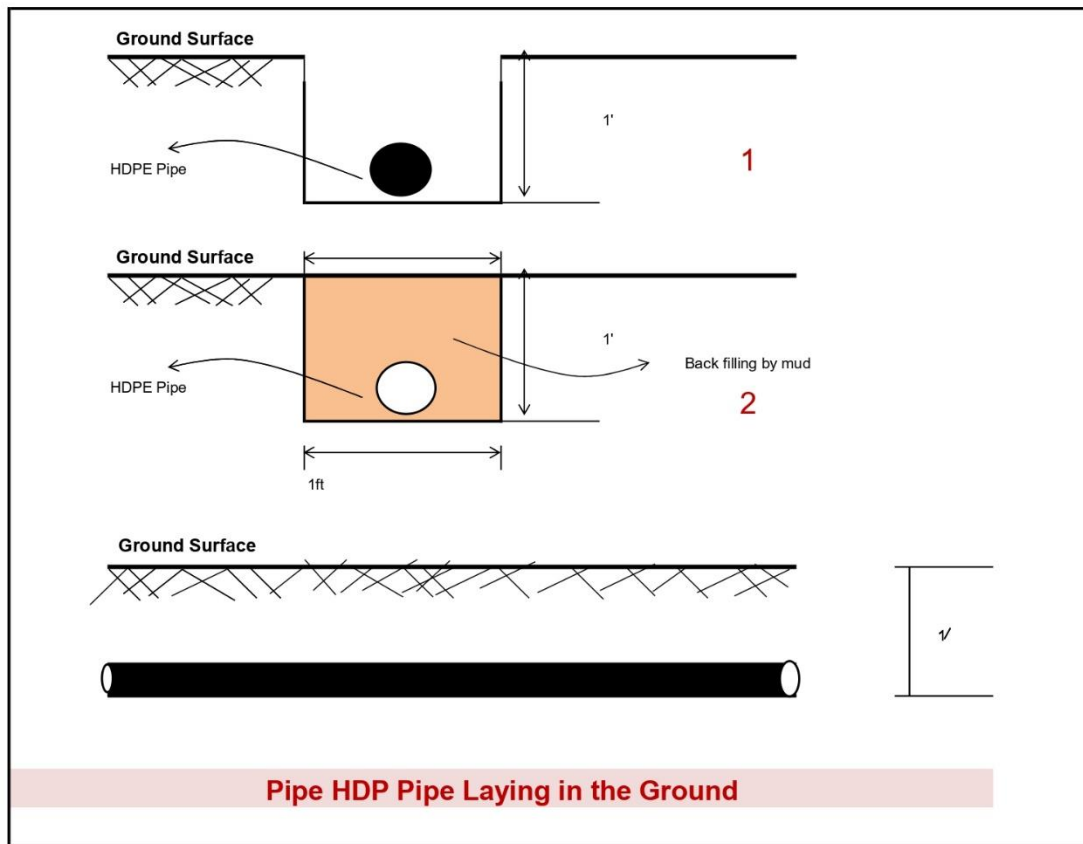

**ANNEXURE A:**
**LOT NO. 2**

Muslim Aid Pakistan					
Rehabilitation & Construction of WASH facilities in Bagh-AJK					
<b><u>BILL OF QUANTITIES</u></b>					
<b>Type of Latrine: Twin Pour Flush Water Sealed Latrine/Sanitation Block</b>					
<b>Sr #</b>	<b>Item Description</b>	<b>Unit</b>	<b>Quantity (QTY)</b>	<b>Unit Rate (PKR)</b>	<b>Amount (PKR)</b>
1	Excavation in foundation of building, bridges and other structures, including dagbelling, dressing, refilling around structure with excavated earth, watering and ramming lead up to one chain (30 m) and lift up to 5 ft. (1.5 m) in ordinary soil	Cft	246.81		
2	Dry rammed brick or stone ballast, 1½" to 2" (40 mm to 50 mm) gauge.	Cft	39.02		
3	Cement concrete plain including placing, compacting, finishing and complete (including screening and washing aggregate) Ratio 1: 4: 8	Cft	36.06		
4	Cement concrete plain including placing compacting, finishing and curing complete (including screening and washing of stone aggregate) Ratio 1: 2: 4	Cft	15.56		
5	Pacca brick work in ground floor: - cement, sand mortar: - Ratio 1:6	Cft	466.86		
6	Providing and laying reinforced cement concrete (including prestressed concrete), using coarse sand a etc.) Reinforced cement concrete in roof slab, beams, columns lintels, girders and other structural members laid in situ or precast laid in position, or prestressed members cast in situ, complete in all respects. Type C (nominal mix 1: 2: 4)	Cft	44.43		
7	Fabrication of mild steel reinforcement for cement concrete, including cutting, bending, laying in position, making joints and fastenings, including cost of binding wire and labour charges for binding of steel reinforcement (also includes removal of rust from bars)	Kg	150.00		
8	Cement plaster 1:4 up to 20' (6.00m) height:- 1/2" thick	Sft	899.25		

9	Aluminum Hand Rail for Disabled persons (Ramp) So that they may use it for their easy access. HT Pole 2 sides, 7 feet length 50mm & VT Pole 25mm both distance 8 inch Complete in all aspects as decided by Engineer in charge at site. As specified by Engineer (1/7 Slop)	Job	1.00		
10	Electrification complete in all respect Wire GM Cable, Pakistan, Newage 40 rft 7/29 and button Abid company, Pipe popular, beta and deluxe Company, Borad Good Quality .Approved by the Engineer.	Job	1.00		
11	painting with three coats of weather-resistant paint, including wall puttying of all outer and inner walls, logo on surfacing, using approved paints and colour pigments complete in all respects as per the approve and direction of the engineer in charge.	Sft	899.25		
12	Shuttering for RCC roof (wooden or steel plate with pole.)	Sft	96.00		
13	P/F C.P BIB COCK ii) 1.5 cm (1/2") Super Master	No	10		
14	Handel value 1/2-inch China	No	2		
15	plug 1/2 inch	No	2		
16	Providing and Laying water tank 500 Gallons Three Ply (Dura) or equal.	No	1		
17	P/L cutting jointing testing and disinfecting I.L.L pipe line in trenches with socket joints using I.L.L pipe COMPLETE in all respects with specials and value medium quality. 3/4" Dia	Rft	100		
18	P/L cutting jointing testing and disinfecting I.L.L pipe line in trenches with socket joints using I.L.L pipe COMPLETE in all respects with specials and value medium quality. 1/2" dia	Rft	20		
19	Supplying and laying polythene sheet over D.P.C. under floors and on roofs, etc. 500 gauge (.005" thick)	Sft	96.00		
20	P/F glazed earthen ware water closet squatter type with foot rest white i/c p-trap 4" glazed. (Master) English- type commode with Muslim shower for Disable. (one Indian seat and one English command)	No	2		
21	PVC Pipe 4" Dia 13' Length complete in all respect Class	No	2		

22	PVC Pipe 2" Dia 10' Length complete in all respect Class	No	2		
23	Tee, union, socket, Elbow and end cap B Class 1/2inch & taps.	No	16		
24	2.5'x6' iron door with fixing 1.5"x1.5" angle iron and using of 18SWG iron sheet and 2 coat final painting as using in schools construction. Approved by the Engineer.	No	1		
25	Ceramic Tile Work in front side of Tank (7.5' x3'), Floor area (7.5' x3'), in hand washing area at water collection area. Aishe White Color of tiles or as directed by WASH Officer.	Sft	30		
26	3'x6' iron door with fixing 1.5"x1.5" angle iron and using of 18SWG iron sheet and 2 coat final painting as using in schools construction. Approved by the Engineer.	No	1		
27	Steel Ventilator (1'x1.5') Approved by the Engineer.	No	2		
28	Visibility (Logo Muslim aid & steel plate 2'x2'with writing)	No	1		
<b>Total amount in PKR for one Sanitation Block</b>					
<b>Total amount PKR for 04 Sanitation Blocks</b>					

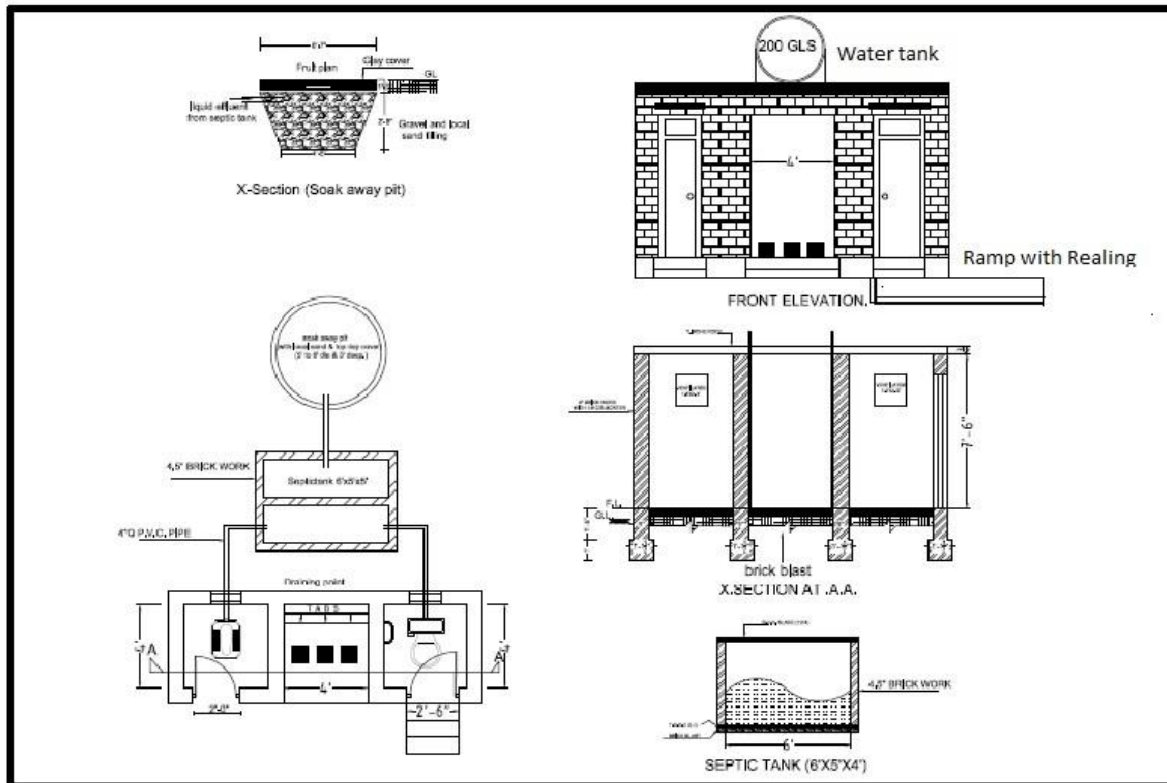

**PLAN OF POUR FLUSH LATRINES FOR PERSON WITH SPECIAL NEED**

### GENERAL SUMMARY OF DWSS

GENERAL SUMMARY OF DWSS		
<b>Lot No. 1</b>	Rehabilitation of DWSS Al Shaikh Basti Bagh AJK	
	Rehabilitation of DWSS Major Camp Huda Bari	
<b>Lot No. 2</b>	Rehabilitation & Construction of WASH facilities in Bagh-AJK	
<b>GRAND TOTAL LOT 1 &amp; 2</b>		

Contractor' Signatures & Seal \_\_\_\_\_

QUANTITY / ANY OTHER DISCOUNTS (PLEASE SPECIFY):

THE PROPOSED DISCOUNTS WILL BECOME AN INTEGRAL PART OF YOUR BID SUBMISSION

PAYMENT TERMS: ACCEPTANCE OF PAYMENT TERMS (I.E. 30 DAYS NET FROM RECEIPT OF DOCUMENTS)

YES: \_\_\_\_\_ NO: \_\_\_\_\_

BIDDERS NAME AND SIGNATURE: \_\_\_\_\_



## **ANNEXURE B**

### **(General Terms and Conditions for Purchase/Services for Rehabilitation/Construction of DWSS & WASH Facilities in Bagh-AJK)**

#### **1. ACCEPTANCE OF THE PURCHASE ORDER**

This Purchase Order may only be accepted by the supplier/Contractor signing and returning an acknowledgment copy of it or by timely delivery of the **Rehabilitation/Construction of DWSS & WASH Facilities in Bagh-AJK** in accordance with the terms of the Purchase Order/Contract as herein specified. Acceptance of this Purchase Order shall affect a contract between the Parties under which the rights and Obligations of the parties shall be governed solely by the terms and conditions of the purchase order including these General Conditions. No additional or inconsistent provision proposed by the supplier /Contractor shall bind **Muslim Aid (MAP)** unless agreed to in writing by a duly authorized **Muslim Aid (MAP)** official.

#### **2. LEGAL STATUS**

The supplier / Contractor shall be considered as having the legal status of an independent contractor vis-à-vis **Muslim Aid (MAP)**. The Supplier / Contractor, its personnel, and sub-contractors shall not be considered in any respect as being the employees of **Muslim Aid (MAP)**. The supplier / Contractor shall be fully responsible for all work and services performed by its employees and for all acts and omissions of such employees.

#### **3. SOURCE OF INSTRUCTION**

The supplier / Contractor shall neither seek nor accept instructions from any authority external to **Muslim Aid (MAP)** in connection with the performance under this contract. The Supplier / Contractor shall refrain from any action that may adversely affect **Muslim Aid (MAP)** and shall fulfill its commitments with the fullest regard to the interests of **Muslim Aid (MAP)**.

#### **4. ANTI-PERSONNEL MINES**

The supplier / Contractor guarantees that it is not engaged in the sale or manufacture, either directly or indirectly, of anti-personnel mines or any components produced primarily for the operation thereof. Any breach of this representation and warranty shall entitle **Muslim Aid (MAP)** to terminate this Purchase Order immediately upon notice to the supplier / Contractor, at no cost to **Muslim Aid (MAP)**.

#### **5. CHILD LABOUR**

The supplier / Contractor represents and warrants that neither it, nor any of its suppliers, is engaged in any practice inconsistent with the rights outlined in the Convention on the Rights of the Child, including Article 32 thereof, which, *inter alia*, requires that a child shall be protected from performing any work that is likely to be hazardous or to interfere with the child's education, or to be harmful to the child's health and physical, mental, spiritual, moral or social development. Any breach of this representation and warranty shall entitle **Muslim Aid (MAP)** to terminate this Purchase Order immediately upon to the supplier, at no cost to **Muslim Aid (MAP)**.

#### **7. SUB-CONTRACTING**

In the event the Supplier / Contractor require the services of a sub-contractor, the supplier / Contractor shall obtain the prior written approval of **Muslim Aid (MAP)** for all sub-contractors. The supplier / Contractor shall be fully responsible for all work and services performed by its sub-contractors and suppliers and for all acts and/or omissions of such sub-contractors and supplier and their personnel. The approval of **Muslim Aid (MAP)** of a sub-contractor shall not relieve the Supplier / Contractor of any of its obligations under this Purchase Order. The terms of any sub-contract shall be subject to and conform to the provision of this Order.

#### **8. ASSIGNMENTS**

The supplier / Contractor shall not assign, transfer, pledge, or make other disposition of this Order or any part thereof or of any of the supplier's / Contractor rights, claims, or obligations under this Order except with the prior written consent of **Initiative of Change (MAP)**.

#### **9. OFFICIALS NOT TO BENEFIT**

The supplier / Contractor represents and warrants that no official of **Muslim Aid (MAP)** has been, or shall be, offered by the Supplier / Contractor any direct or indirect benefit arising from this order or the award thereof. The supplier / Contractor agree

that a breach of this provision is breach of an essential term of this Order.

#### **10. ENCUMBRANCES/LIENS**

The supplier / Contractor shall not cause or permit any lien, attachment or other encumbrance by any person or entity to be placed or to remain in any public office or with Muslim Aid (MAP) against any monies due or to become due for any work done or materials furnished under this contract, or by reason of any other claim or demand against the Supplier / Contractor.

#### **11. EXPORT LICENCE**

The order is subject to the obtaining of any export license or other government authorization that may be required. It shall be the responsibility of the Supplier / Contractor to obtain such license or authorization. Should the supplier / Contractor encounter difficulties in obtaining the required export license or governmental authorization, it shall immediately bring this to the attention of Muslim Aid (MAP). Muslim Aid (MAP) will, at its discretion, use its best endeavors to assist.

#### **12. WARRANTY**

The supplier / Contractor warrants the material, construction, including finishing under this Order conform to the specification of the Order and is free from damage and defects in workmanship or materials. This warranty is without prejudice to any further guarantees that the Supplier / Contractor provides to purchasers. Such guarantees shall apply to the construction subject to this Order.

#### **13. REJECTION**

Under the Order, Muslim Aid (MAP) shall have the right to reject the material or any part thereof if they do not conform to specifications.

#### **14. INSPECTION**

Muslim Aid (MAP) or its duly accredited representative shall have the right to inspect the material / Construction work ordered for under this Order at Supplier's stores, during manufacture, in the port or places of shipment, and the Supplier shall provide all facilities for such inspection.

#### **15. OVERRIDING CLAUSE**

In the event of any conflict or inconsistencies between these General Terms and Conditions for construction or any other document which forms part of the purchase these conditions shall prevail except where they have been amended (by specific reference to the relevant clause and paragraph of these Conditions) as provided for herein.

#### **16. FORCE MAJEURE: OTHER CHANGES IN CONDITIONS**

In the event of as soon as possible after the occurrence of any cause constituting force majeure, the Supplier shall give notice and full particulars in writing to Muslim Aid (MAP) of such occurrence or change if the Supplier / Contractor is hereby rendered unable.

Wholly or in part, to perform its obligations and meet its responsibilities under this Order. The Supplier / Contractor shall also notify Muslim Aid (MAP) of any other changes in conditions or the occurrence of any even which interferes or threatens to interfere with its performance of this purchase Order. On receipt of the notice required under this Article, Muslim Aid (MAP) shall take such action as, in its sole discretion; it considers to be appropriate or necessary in the circumstances, including the granting to the Supplier of a reasonable extension of time in which to perform its obligations under this Purchase Order.

If the Supplier / Contractor is rendered permanently unable, wholly or in part, by reason of force majeure to perform its obligations and meet its responsibilities under this Order, **Muslim Aid Pakistan (MAP)** shall have the right to suspend or terminate this Purchase Order on the same terms and conditions as are provided for in Article 18, "Termination", except that the period of notice shall be seven (7) days instead of thirty (30) days.

Force majeure as used in this provision means acts of God, war (whether declared or not), invasion, revolution, insurrection, or other acts of similar nature or force.

Notwithstanding anything to the contrary in this Order, the Supplier / Contractor recognizes that the work and services will be performed under harsh or hostile conditions caused by civil unrest. Consequently, delays or failure to perform caused by events arising out of or in connection with, such civil unrest shall not, in and to itself, constitute force majeure under this Order.

#### **17. DISPUTES – ARBITRATION**

**Amicable Settlement** the Parties shall use their best efforts to settle amicably any dispute, controversy or claim arising out of this Order or the breach, termination or invalidity thereof. Where the parties wish to seek such an amicable settlement through conciliation, the conciliation shall take place.

## 18. TERMINATION OF PURCHASE ORDER

In the case of failure by the Supplier / Contractor to fulfill its obligations under the terms and conditions of the Order including but not limited to failure to obtain necessary export licenses, or failure or refusal to make delivery of all or part of the goods by the agreed delivery date or dates, **Muslim Aid Pakistan (MAP)** may, after giving the Supplier / Contractor reasonable notice to perform without prejudice to any other rights or remedies excess on or more of the following rights.

- Procure all or part of the goods from other sources, in which event **Muslim Aid Pakistan (MAP)** may hold the Supplier / Contractor responsible for any excess cost occasioned thereby.
- Refuse to accept delivery of all or part of the scope of work.
- Cancel this Order without any liability for termination charges to **Muslim Aid Pakistan (MAP)**.

**Muslim Aid (MAP)** may terminate forthwith this Order at any time should the mandate or the funding of **Muslim Aid Pakistan (MAP)** be curtailed or terminated in which case the Supplier / Contractor shall be reimbursed by **Muslim Aid Pakistan (MAP)** for all reasonable costs incurred by the Supplier / Contractor prior to receipt of the notice of termination.

## 19. INSOLVENCY AND BANKRUPTCY

Should the Supplier / Contractor become insolvent or should control of the Supplier / Contractor change by virtue of insolvency, **Muslim Aid Pakistan (MAP)** may without prejudice to any other rights and remedies, terminate this Order by giving the Supplier / Contractor written notice of termination.

Should the Supplier / Contractor be adjudged bankrupt or should the Supplier / Contractor make a general assignment for the benefit its creditors or should a receiver be appointed on account of the Supplier's / Contractor insolvency **Muslim Aid Pakistan (MAP)** may under the terms of this Order.

## 20. PAYMENT INSTRUCTIONS

**Muslim Aid Pakistan (MAP)** shall on the fulfillment of the Delivery Terms / Completion of work, unless otherwise provided in this Order make payment by cross cheque in the name of the company within thirty days of receipt of the Suppliers / Contractor invoice along with the work done certificate from the Muslim Aid Engineer and copies of any other documentation specified in the Order.

Payment against the invoice referred to above will reflect any discount shown under the payment terms of this Order, provided payment is made within the period required by such payment terms.



20. Working Languages:

English       French       Spanish       Russian       Arabic       Chinese       Other (specify)

21. Bank Name:

22. Branch Name:

31. Routing Bank details (if applicable): full details to be provided as per above

**Section 2: Banking Information**

- |   |                              |
|---|------------------------------|
| 23. Branch Address:                           | 24. Tel. number:             |
| 25. Fax number:                               | 26. Account Name: Swift/Bank |
| 27. Bank Account Number:                      | 28. Identifier Code (BIC):   |
| 29. Account currency:                         |                              |
| 30. International Bank Account Number (IBAN): |                              |

**Section 3: Technical Capability and Information on Goods / Services Offered**

32. Quality Assurance Certification (e.g. ISO 9000 or Equivalent) (please provide a Copy of your latest Certificate):

33. For Goods only, do those offered for supply conform to National/International Quality Standards?

Yes  No

34. List below up to a maximum of ten (10) of your core Goods/Services offered:

**Description (one Line for each Item National/International Quality Standard to which Item conforms)**

---



---



---



---



---



---



---



---



---



---

---

---

---

---

---

---

**Section 5: Official not to benefit**

38. By signing this VRF, potential vendors confirm that they have read, understood and will comply with the MUSLIM AID policy on the “zero tolerance” that strictly prohibits the acceptance of any type of gift and/or hospitality by MUSLIM AID

Yes  No  Any breach of this clause may lead to the termination of all contracts your Company may

Name:  
Functional Title:  
Signature:  
Date:

**Please courier the completed BID documents to:**

**Procurement Department Muslim Aid**

**Plot # 1, First Floor, Executive Business Centre, Main Double Road, FECHS,**

**E-11/2, Islamabad**

## **INSTRUCTIONS FOR COMPLETION OF BID**

**The form should be typewritten in uppercase** and completed clearly and accurately ensuring that all questions are answered. The numbers below correspond to item numbers on the registration form:

### **Section 1:**

1. Full name of company.
2. Full street address.
3. Full mailing address (including P.O. Box, if any).
4. Telephone number, including correct country and area codes.
5. Fax number, including country and area codes.
6. Email address.
7. WWW Address.
8. Provide name of person (including title) or department to whom correspondence should be addressed.
9. Provide email address of contact person.
10. Full legal name of parent company, if any.
11. Please provide, on a separate sheet, if necessary, names and addresses of all subsidiaries & associates if any.
12. Please provide countries where the company has local offices or representation.
13. Please tick one box. If other; please specify.
14. Please tick one box. If other; please specify. If the company is a manufacturer of some products and a trader/agent of others which they do not manufacture, both boxes should be ticked.
15. Indicate the year in which the organization was established under the name shown in Item 1.
16. Indicate the total number of full-time personnel in the company.
17. Provide the license number under which the company is registered, or the State where it is registered.
18. Provide the VAT number or Tax I.D. of the company.
19. Please tick the boxes for which languages the company is able to provide technical documents. Please specify other languages.
20. Please tick the boxes for which languages the company is able to work in. Please specify other languages.

### **Section 2:**

21. Full name of bank.
22. Name of branch.



23. Address where branch is located.
24. Telephone number, including correct country and area codes.
25. Fax number, including country and area codes.
26. Number of the company account.
27. Name in which the account is held (**important:** this should be the company name).
28. Currency of the account.
29. Swift code for the account.  
International Bank Account Number (IBAN).
30. Should a routing be required for international payments, please provide full details of intermediate bank(s).

**Section 3:** (Documents to be submitted with Bids)

31. Pakistan Engineering Council Certificate (Validity)
32. NTN certificate
33. Statement of work
34. Company Key personal staff for this project
35. Work Plan for the construction of civil work
36. Construction Equipment list
37. Proof of Similar Project executed for last five years (List plus POs)
38. Project in Hand (List plus POs)
39. Financial Statement
40. Affidavit showing that the company is not involved in any litigation.
41. General Reputation (Provide the evidence of completion certificates of at least two previously completed projects of clients)

END